

## Installation Instructions

### PDD-08R-Wi (Wireless VAV Omni-Directional Displacement)

1. Connect Thermostat Controller to 24V building power source at designated location – power cable is typically run from ceiling through pre-cut opening in wall behind Thermostat mounting position.
2. Connect Wireless Concentrator to Thermostat (3 wires – 24VAC Power, 0-10VDC Heat, 0-10VDC Cool).
3. Lay all Prestige Wireless Diffusers designated for current zone on easily accessible surface (table, etc.) (maximum 32 diffusers).
4. Press and hold Sync Button on Wireless Concentrator for approximately 5 seconds – LED indicator light will begin to flash green in 1 second intervals (1 second on, 1 second off), indicating that it is in Pairing Mode. NOTE: The Wireless Concentrator will remain in Pairing Mode for a 15-minute window once activated.
5. Power on first Wireless Diffuser by connecting battery to control boards. To do this, locate two loose wires (one connected to battery, one split between the control boards). Each wire has a matching connector on the end, which fit together. Once connected, the LED indicator light will illuminate red for 2 seconds, then turn off.
6. Press and hold Sync Button on Wireless Diffuser for approximately 5 seconds – LED indicator light will flash green three times, then turn off for 5 seconds. This display (flashing three times, then turning off for 5 seconds) will repeat until the unit has successfully paired with the Wireless Concentrator. Once paired, the LED indicator light will remain off.
7. Repeat Steps 5 & 6 for each remaining Wireless Diffuser, until all diffusers in the zone are paired. NOTE: The 15-minute pairing mode window for the Wireless Concentrator will restart every time a new Wireless Diffuser is paired.
8. Once pairing process is complete, press sync button on Wireless Concentrator to terminate pairing mode. In idle mode, the LED indicator light will remain off.
9. Place each Wireless Diffuser in a pre-cut 8-5/16"Ø (211mm) floor opening. Tighten center screw to lock retention bar against underside of raised access floor panel and secure diffuser in place.
10. Mount Wireless Concentrator inside wall below thermostat, through opening cut for thermostat power cable.
11. Mount thermostat to wall over pre-cut opening.

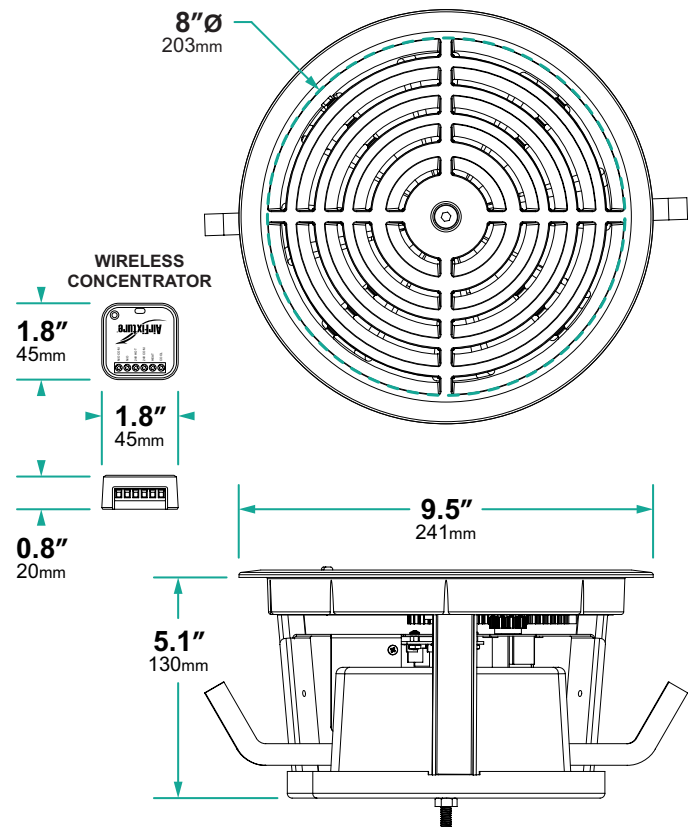
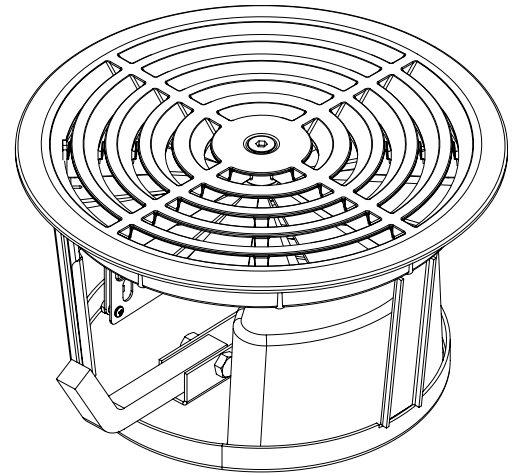

ALL DIMENSIONS NOMINAL +/- 0.1" (2.5mm)

REFER TO PAGE 2 FOR IC / FCC COMPLIANCE

## Installation Instructions

# PDD-08R-Wi (Wireless VAV Omni-Directional Displacement)

### IC Compliance

This device complies with Industry Canada's licence-exempt RSSs. Operation is subject to the following two conditions:

- (1) This device may not cause interference; and
- (2) This device must accept any interference, including interference that may cause undesired operation of the device.

Cet appareil est conforme aux CNR exempts de licence d'Industrie Canada. Son fonctionnement est soumis aux deux conditions suivantes :

- (1) Ce dispositif ne peut causer des interférences ; et
- (2) Ce dispositif doit accepter toute interférence , y compris les interférences qui peuvent causer un mauvais fonctionnement de l'appareil.

This radio transmitter (identify the device by certification number) has been approved by Industry Canada to operate with the antenna types listed below with the maximum permissible gain indicated. Antenna types not included in this list, having a gain greater than the maximum gain indicated for that type, are strictly prohibited for use with this device.

Cet émetteur radio (identifier le périphérique par numéro de certification) a été approuvé par Industrie Canada pour fonctionner avec les types d'antenne énumérés ci-dessous avec le gain maximal admissible indiqué. Les types d'antennes ne figurant pas dans cette liste, ayant un gain supérieur au gain maximum indiqué pour ce type, sont strictement interdits pour une utilisation avec cet appareil.

### FCC Compliance

This equipment has been tested and found to comply with the limits for a Class B digital device, pursuant to Part 15 of the FCC Rules. These limits are designed to provide reasonable protection against harmful interference in a residential installation. This equipment generates, uses and can radiate radio frequency energy and, if not installed and used in accordance with the instructions, may cause harmful interference to radio communications. However, there is no guarantee that interference will not occur in a particular installation. If this equipment does cause harmful interference to radio or television reception, which can be determined by turning the equipment off and on, the user is encouraged to try to correct the interference by one or more of the following measures:

- Reorient or relocate the receiving antenna.
- Increase the separation between the equipment and receiver.
- Connect the equipment into an outlet on a circuit different from that to which the receiver is connected.
- Consult the dealer or an experienced radio/TV technician for help.

Changes or modifications not expressly approved by the party responsible for compliance could void the user's authority to operate the equipment.

PATENT PENDING