

Standard Installation & Troubleshooting

Élan-10R-360-Wi-FF

Wireless Underfloor Air Terminal (Variable Volume)

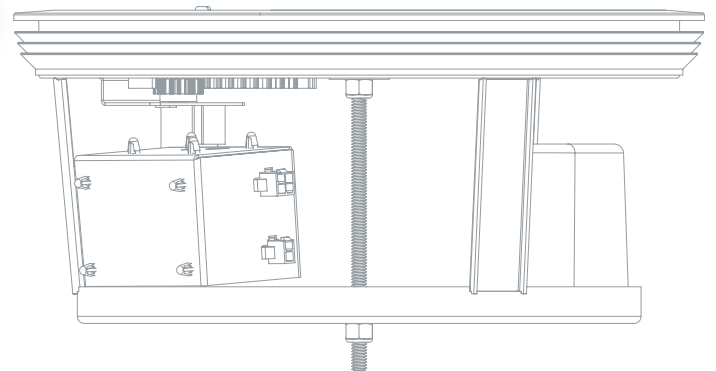
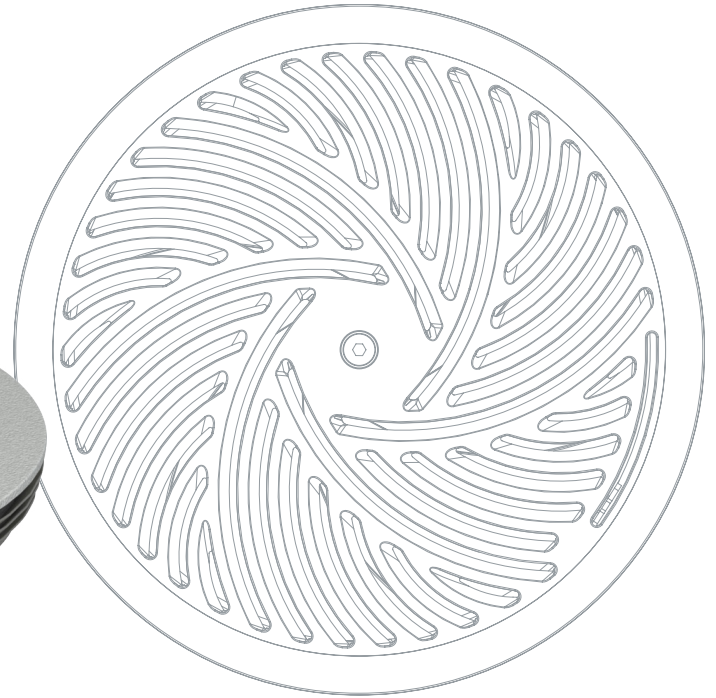
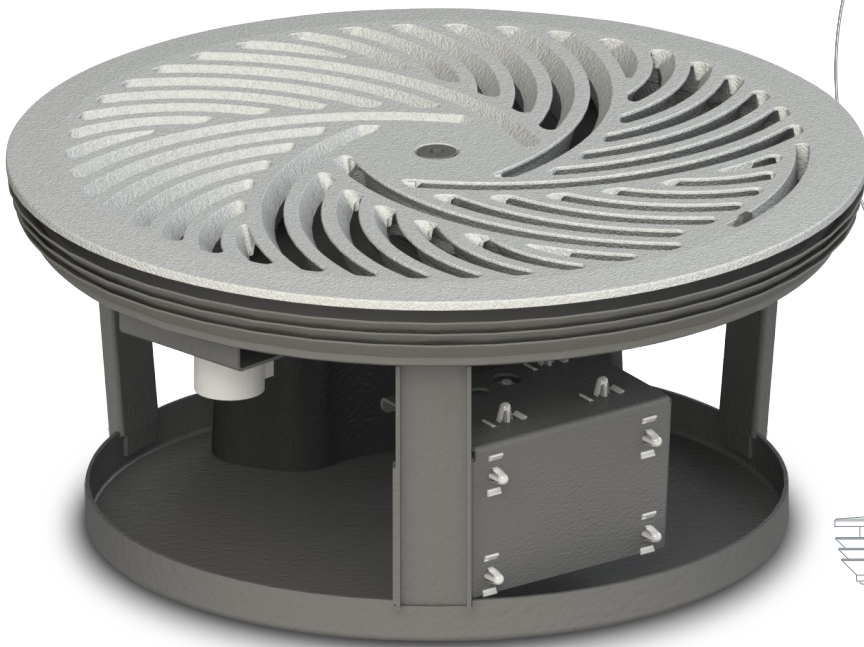

Control Locations & Initial Setup	2
Pairing Process	3
Installation Process	4
Maintenance & Commissioning Mode.....	5
General Troubleshooting & Red LED Status.....	6
Index (Indicators & Functionality)	7-8
Diffuser Troubleshooting	9
IC / FCC Compliance	10



Standard Installation & Troubleshooting

Élan-10R-360-Wi-FF Wireless Underfloor Air Terminal (Variable Volume)

Control Locations

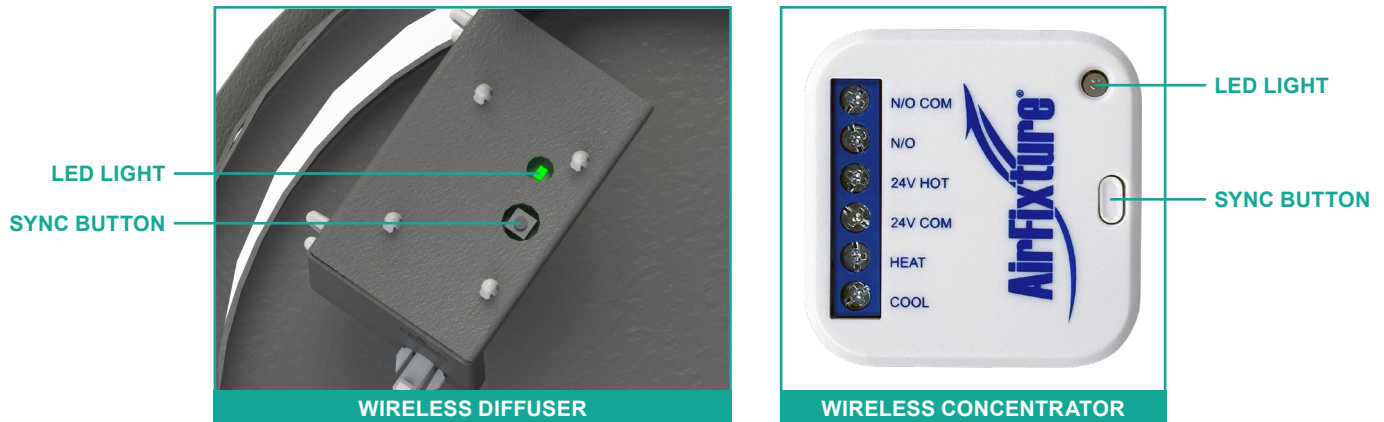

Initial Setup

1. Connect thermostat to 24V building power source at designated location. Power cable is typically run from ceiling through pre-cut opening in wall behind thermostat mounting position.
2. Connect wireless concentrator to thermostat (3 wires – 24V Hot, 24V Common, 0-10VDC Cooling Signal) (**FIGURE 1**).
3. Lay all Prestige wireless diffusers designated for current zone on easily accessible surface (table, etc.) with the diffuser grille face-up (matching installation orientation). A maximum of thirty-two (32) diffusers can be connected in a single zone.

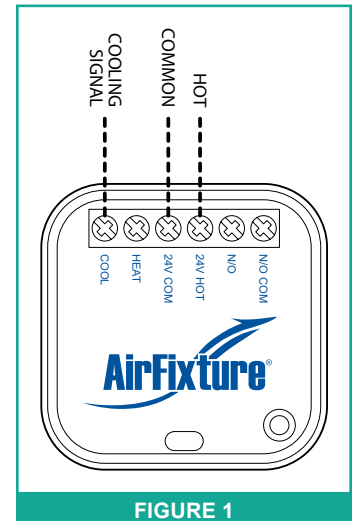

Standard Installation & Troubleshooting

Élan-10R-360-Wi-FF Wireless Underfloor Air Terminal (Variable Volume)

Pairing Process

At the Wireless Concentrator:

1. Press and hold the button on the concentrator for 5 seconds and release. The LED will begin to flash **GREEN** in 1 second intervals (1 second on, 1 second off), indicating that it has entered pairing mode. Once activated, the concentrator will remain in pairing mode for a 15-minute window which resets every time a new diffuser is paired.

At the Wireless Diffuser:

2. Power on the first diffuser by connecting the battery to the control boards. To do this, locate the two loose wires (one connected to battery, one split between the control boards) (**FIGURE 2**). Each wire has a matching connector on the end, which fit together. Once connected, the LED will light up **RED** for 2 seconds, then turn off. Wait for the damper to cycle open to fully closed.

NOTE: DO NOT manually rotate the motorized damper plate while unit is powered on, as this could result in damage to the circuitry.

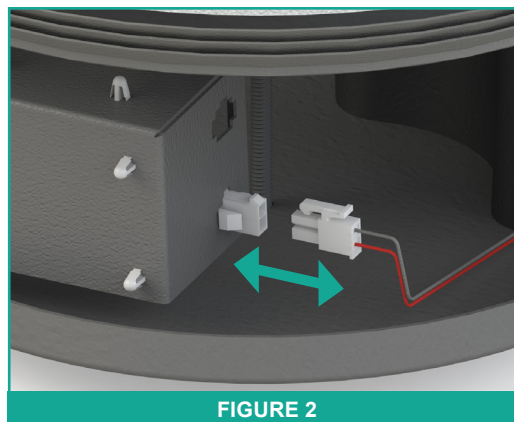

3. Press and hold the button on the diffuser for 5 seconds, then release. The LED will flash **GREEN** three times, then light up for 5 seconds. This will repeat until the unit has successfully paired with the concentrator. Once paired, the LED will remain off under normal operation.
4. Repeat Steps 2 & 3 for each remaining diffuser, until all diffusers in the zone are paired (up to a maximum of 32).

Standard Installation & Troubleshooting

Élan-10R-360-Wi-FF Wireless Underfloor Air Terminal (Variable Volume)

Installation Process

Once paired and tested for functionality, diffusers are ready for installation.

Tools Required:

1. Panel Lifter (suction cups) - remove floor panels
2. Jigsaw - cut opening in floor panel (if panels are not pre-cut)
3. Carpet Knife - cut opening in carpet tile / floor covering

Preparation:

1. Verify that the Élan-10R-360-Wi-FF is the correct model, unit count and location(s) per scheduled placement.
2. Remove the floor covering / floor panel at the desired location(s) (if installed).
3. Verify that all adjacent floor panels are securely installed.

Installation:

1. Remove the floor panel and cut a 10.9"Ø [+0.125"/-0"] (277mm [+3.175/-0.00]) round opening for the Élan terminal. Cut opening in carpet tile using same dimensions / position. Replace floor panel / carpet tile when finished.
2. With the Élan terminal positioned over the opening, place receiver antenna near the opening as shown (FIGURE 3). It is designed to rest between top of floor panel and carpet tile.
3. With the antenna in position, insert the Élan terminal firmly down into the opening in the floor panel. The friction fit gasket will hold the unit securely in place.

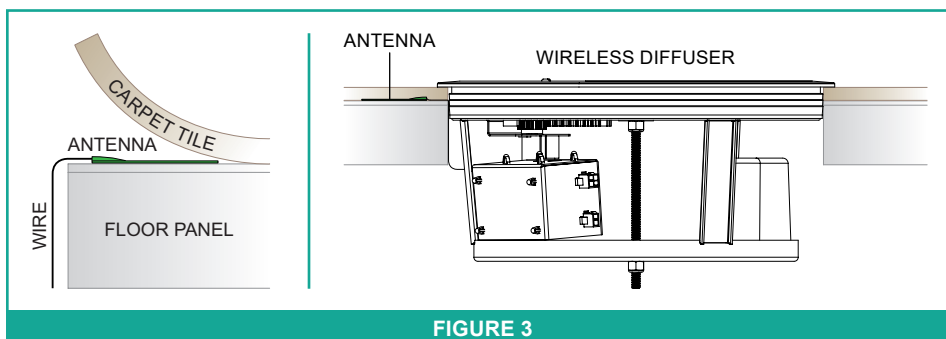
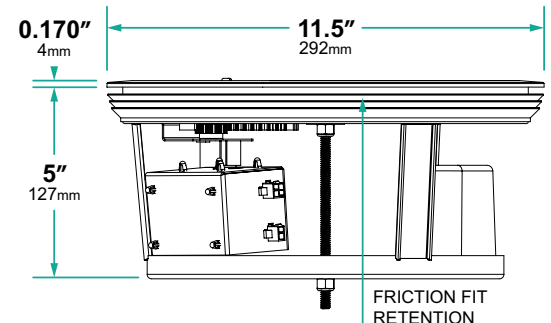
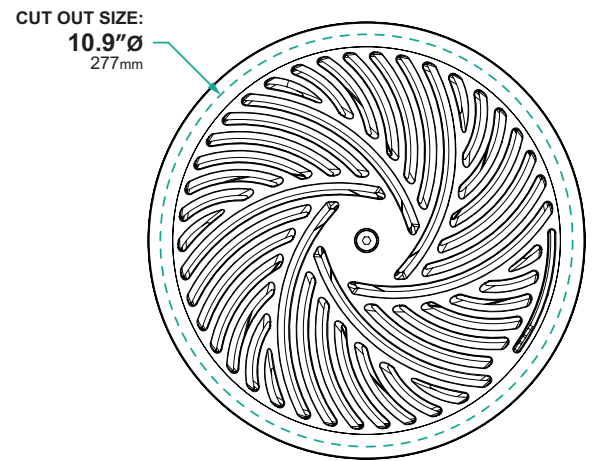
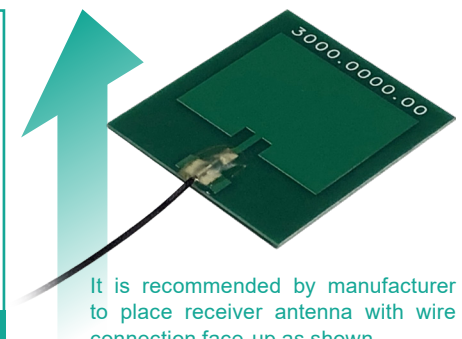

FIGURE 3



It is recommended by manufacturer to place receiver antenna with wire connection face-up as shown.

Standard Installation & Troubleshooting

Élan-10R-360-Wi-FF Wireless Underfloor Air Terminal (Variable Volume)

Maintenance

To Remove Debris From Catch Pan:

1. Lift unit up out of installation opening as far as possible. Keep unit level; tilting it too far may cause debris to dump out under the floor.
2. While holding unit, carefully vacuum debris out of the catch pan.
3. Lower unit back down into floor. Press it down firmly, so that friction fit gasket will hold it in place.

To Replace Battery:

1. Lift unit up out of installation opening, and carefully place it upside-down on top of floor.
2. Disconnect mox cable from control board housing.
3. From the bottom side of the catch pan, use a phillips head screwdriver to remove the three (3) retaining screws securing the battery to the catch pan (**FIGURE 4**).
4. Position replacement battery in the catch pan, and secure it in place using the retaining screws.
5. Connect mox cable from new battery to control board housing.
6. Lower unit back down into floor. Press it down firmly, so that friction fit gasket will hold it in place.

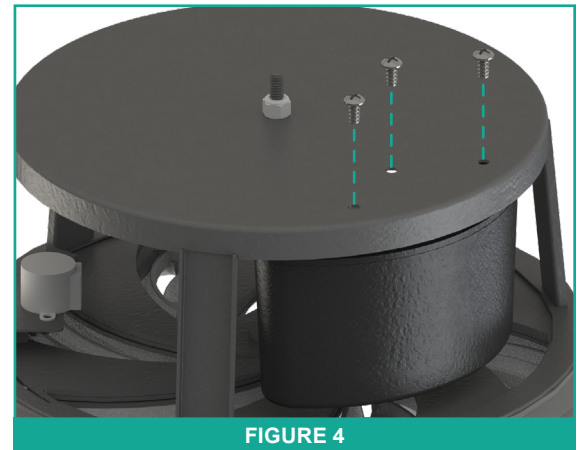

FIGURE 4

Commissioning Mode

At the Wireless Concentrator:

1. Once you have completed the initial pairing, press the button on the concentrator. The LED will flash **ORANGE** in 1 second intervals, indicating that the concentrator has entered 'Identify Mode'.

At the Wireless Diffuser:

2. Within 5 minutes of entering the 'Identify Mode' on the concentrator, the LED on all diffuser(s) connected to the identifying concentrator will light up and remain a steady **GREEN**, and the motorized damper will fully open.

To exit 'Identify Mode', press the button the concentrator and the LED will stop blinking. Within 5 minutes, the LED on the diffusers will turn off and the diffuser will resume normal operation.

Standard Installation & Troubleshooting

Élan-10R-360-Wi-FF Wireless Underfloor Air Terminal (Variable Volume)

General Troubleshooting

1. When an error is detected in the zone, the concentrator LED will light up solid **RED** and remain on.
2. Confirm that all diffusers are paired to the same concentrator by entering Commissioning Mode.
3. Inspect each diffuser’s LED to confirm color. It is not necessary to remove the diffuser from the floor to see the light; it is visible from above, through the grille.
4. If the diffuser LED is **GREEN**, and the motorized damper plate is completely open, the diffuser is functioning correctly.
5. If the diffuser LED is not visible, check if the manual damper plate has been closed. If so, open it.
6. If the diffuser LED is still not visible once the plate is open, use a low-torque screw gun to loosen the center retention screw and remove the diffuser from the floor.
7. Press and hold the diffuser button for 5 seconds, then release. If the LED lights up solid **GREEN**, the diffuser is connected to a concentrator; however, it may be a concentrator located in a different zone. If the LED starts flashing **RED**, refer to the table below.
8. Once the error has been corrected, press and hold the button on the concentrator until the **RED** LED light changes from solid to flashing. The light will flash **RED** ten (10) times, then turn off. If the light remains off, the fault in the zone has been cleared (during normal operation the light will remain off).
9. If the concentrator LED once again lights up solid **RED**, there is likely another error with a different diffuser in the zone.

RED LED Status

LED BEHAVIOR	DESCRIPTION	SOLUTION
LED flashes RED one (1) time every 5 seconds	Low battery	Replace battery
LED flashes RED two (2) times every 4 seconds	UART error (no UART response from motor control board for 25 minutes)	Confirm Orange-Yellow cable connection; if error persists, replace motor control board
LED flashes RED three (3) times every 4 seconds	Lost link with concentrator (no response from concentrator for 25 minutes)	Check wireless antenna connection, then reconnect diffuser using standard pairing procedure; if error persists, replace wireless control board
LED flashes RED five (5) times every 4 seconds	Motor control board issue	Replace motor control board

Standard Installation & Troubleshooting

Élan-10R-360-Wi-FF Wireless Underfloor Air Terminal (Variable Volume)

Index (Indicators & Functionality)

WIRELESS CONCENTRATOR			
CONDITION	BUTTON PRESS	LED STATE	NOTES
Start Up	–	Network Active - GREEN (2 Seconds) <hr style="width: 50%; margin: 0 auto;"/> Network Inactive - RED (2 Seconds)	Behavior of the LED light varies based on current network status. If a network has been created, a GREEN LED is shown. If not, a RED LED is shown instead.
Normal Operation Mode	–	Off	During normal operation, the LED light will remain off.
Join Mode	5 Seconds	Flash GREEN (1 Second ON / 1 Second OFF)	Join Mode remains active for 15 minutes. Each time a new diffuser is joined, the 15 minute active window resets.
Identify Mode	Single Press	Flash ORANGE (1 Second ON / 1 Second OFF)	Identify Mode remains active for 20 minutes. Press button again to exit at any time during active window.
Error State	–	Solid RED	Indicates a communication or mechanical error somewhere in the zone. It is recommended to begin troubleshooting using Identify Mode.
Clear Errors	> 10 Seconds	Flash RED (10 Times, Then Remain OFF)	During the RED flashing sequence, pressing and holding the button for 3+ seconds will factory reset the unit.
Factory Reset	> 10 Seconds	No LED State Specified	Clears all stored network information, then returns to idle mode.

Standard Installation & Troubleshooting

Élan-10R-360-Wi-FF Wireless Underfloor Air Terminal (Variable Volume)

Index (Indicators & Functionality)

WIRELESS DIFFUSER			
CONDITION	BUTTON PRESS	LED STATE	NOTES
Start Up	–	Network Active - GREEN (2 Seconds) <hr style="width: 50%; margin: 0 auto;"/> Network Inactive - RED (2 Seconds)	Behavior of the LED light varies based on current network status. If a network has been created, a GREEN LED is shown. If not, a RED LED is shown instead.
Normal Operation Mode	–	Off	During normal operation, the LED light will remain off.
Pairing Mode	5 Seconds	Flash GREEN (3 Times Every 5 Seconds)	Pairing Mode remains active for 10 minutes. Press or hold button again to exit at any time during active window. If the battery is low or another error is present, the LED will flash RED and fail to join the network.
Identify Mode (Concentrator Initiated)	–	Solid GREEN	Identify Mode remains active for 5 minutes. Press or hold button again to exit at any time during active window. If the battery is low or another error is present, the LED will flash RED and fail to join the network.
Identify Mode (Manually Initiated)	5 Seconds	Solid GREEN	Identify Mode remains active for 5 minutes. Press or hold button again to exit at any time during active window. If the battery is low or another error is present, the LED will flash RED and fail to join the network.
Motor Board Low Battery	–	Flash RED * (1 Time Every 5 Seconds)	The motor board battery is running low.
UART Error	–	Flash RED * (2 Times Every 5 Seconds)	No UART response from the motor board in the last 25 minutes.
Communication Lost	–	Flash RED * (3 Times)	No response from the concentrator in the last 25 minutes.
Motor Board Error	–	Flash RED * (5 Times)	Error detected at the motor board.
Factory Reset	> 10 Seconds	No LED State Specified	Clears all stored network information, then returns to idle mode.

* NOTE: **RED** flashing only occurs in Pairing Mode or Identify Mode.

Standard Installation & Troubleshooting

Élan-10R-360-Wi-FF Wireless Underfloor Air Terminal (Variable Volume)

Diffuser Troubleshooting

NOTE: Before making any changes to wiring or jumper position, confirm diffuser battery is disconnected. When reconnecting battery, confirm motorized damper plate is in fully open position.

NOTE: DO NOT manually rotate the motorized damper plate while unit is powered on, as this could result in damage to the circuitry.

1. Confirm all wires are intact and connected to the correct PINS as shown below.

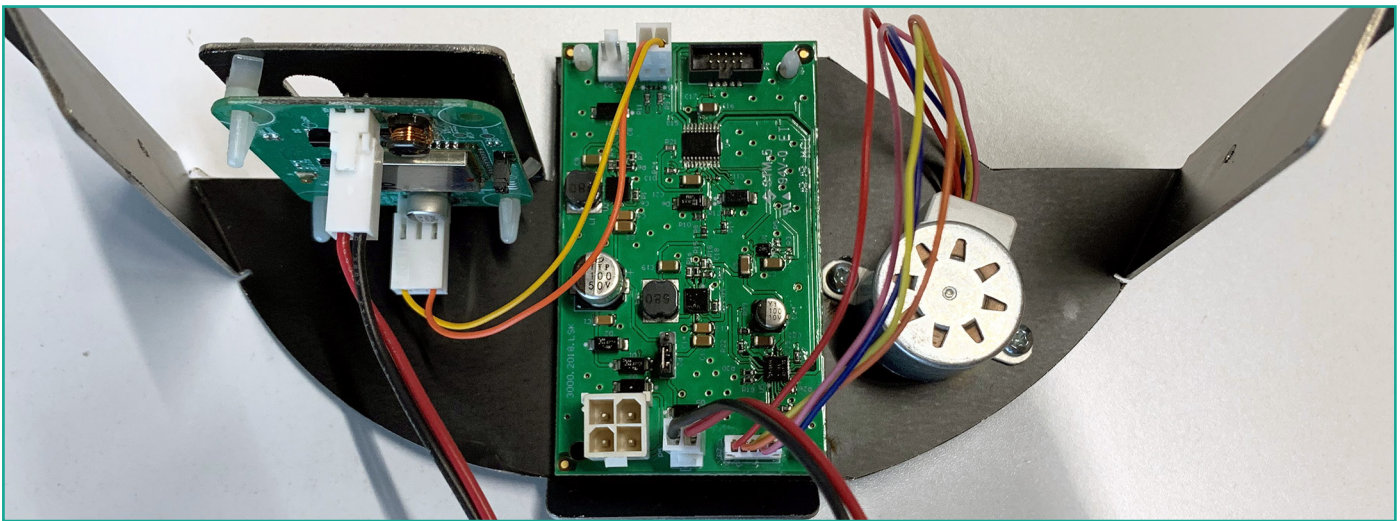

2. Check the jumper position on the motor control board, and confirm it is in PIN-1 and PIN-2 positions.
3. When battery is reconnected and power is restored, check the diffuser LED. If no light is visible:
 - Disconnect battery
 - Connect a standard voltmeter to the battery's 2-PIN molex plug (red/black wires)
 - If voltage is approximately 7.4VDC, then battery is functioning correctly
4. Reconnect battery. If LED is still not illuminated, disconnect battery once again and check connection of red/black Y-cable connected to wireless control board and motor control board:
 - If loose or disconnected, securely reconnect
 - If both ends are connected, the cable is defective; replace the cable
5. Confirm thermostat is set to a known 0-10VDC.
6. Reconnect battery and verify that motorized damper plate moves to fully closed position.
7. Confirm thermostat 0–10VDC is set to 5VDC (50%). If functioning correctly, the motorized damper plate will respond to the thermostat signal, to a 60% open position.
8. If the motorized damper plate still doesn't move, disconnect battery and manually adjust the damper plate by hand to ensure it is free to move. Reconnect battery and confirm that damper plate moves.
9. If motorized damper plate still doesn't move, disconnect the battery and replace the motor.
10. If wireless diffuser still does not function correctly, please contact the manufacturer for additional technical support.

Standard Installation & Troubleshooting

Élan-10R-360-Wi-FF Wireless Underfloor Air Terminal (Variable Volume)

IC Compliance

This device complies with Industry Canada's licence-exempt RSSs. Operation is subject to the following two conditions:

- (1) This device may not cause interference; and
- (2) This device must accept any interference, including interference that may cause undesired operation of the device.

Cet appareil est conforme aux CNR exempts de licence d'Industrie Canada. Son fonctionnement est soumis aux deux conditions suivantes :

- (1) Ce dispositif ne peut causer des interférences ; et
- (2) Ce dispositif doit accepter toute interférence , y compris les interférences qui peuvent causer un mauvais fonctionnement de l'appareil.

This radio transmitter (identify the device by certification number) has been approved by Industry Canada to operate with the antenna types listed below with the maximum permissible gain indicated. Antenna types not included in this list, having a gain greater than the maximum gain indicated for that type, are strictly prohibited for use with this device.

Cet émetteur radio (identifier le périphérique par numéro de certification) a été approuvé par Industrie Canada pour fonctionner avec les types d'antenne énumérés ci-dessous avec le gain maximal admissible indiqué. Les types d'antennes ne figurant pas dans cette liste, ayant un gain supérieur au gain maximum indiqué pour ce type, sont strictement interdits pour une utilisation avec cet appareil.

FCC Compliance

This equipment has been tested and found to comply with the limits for a Class B digital device, pursuant to Part 15 of the FCC Rules. These limits are designed to provide reasonable protection against harmful interference in a residential installation. This equipment generates, uses and can radiate radio frequency energy and, if not installed and used in accordance with the instructions, may cause harmful interference to radio communications. However, there is no guarantee that interference will not occur in a particular installation. If this equipment does cause harmful interference to radio or television reception, which can be determined by turning the equipment off and on, the user is encouraged to try to correct the interference by one or more of the following measures:

- Reorient or relocate the receiving antenna.
- Increase the separation between the equipment and receiver.
- Connect the equipment into an outlet on a circuit different from that to which the receiver is connected.
- Consult the dealer or an experienced radio/TV technician for help.

Changes or modifications not expressly approved by the party responsible for compliance could void the user's authority to operate the equipment.

PRODUCT PATENTED